



Agenda

Access Orangeville Committee Meeting

October 10, 2024, 10:00 a.m.

Electronic and In-Person Participation - Access Orangeville

The Corporation of the Town of Orangeville

(Chair and Secretary at Town Hall - 87 Broadway)

Orangeville, Ontario

NOTICE

Members of the public wishing to view Access Orangeville meetings will have the option to attend in-person, or by calling [+1 289-801-5774](tel:+12898015774) and entering Conference ID: 260 826 207#

Please note that your full name and comments will be part of the public record and will be included in the minutes of the meeting. Prior to the meeting, written comments may be sent to the Committee Secretary by email at gbrennan@orangeville.ca. Such written comments will become part of the public record.

Accessibility Accommodations

If you require access to information in an alternate format, please contact the Clerk's division by phone at 519-941-0440 x 2219 or via email at clerksdept@orangeville.ca.

Pages

1. **Call to Order**

2. **Disclosures of (Direct or Indirect) Pecuniary Interest**

3. **Land Acknowledgement**

We would like to acknowledge the treaty lands and territory of the Williams Treaty Nations and the Mississaugas of the Credit First Nation. We also recognize that Dufferin County is the traditional territory of the Wendat and the Haudenosaunee and is home to many Indigenous people today.

4. **Adoption of Minutes of Previous Meeting**

Recommendations:

That the minutes of the following meeting are approved:

4.1 **2024-09-12 - Access Orangeville - Minutes**

3

5. **Presentations**

5.1 **Councillor A. Macintosh, Chair, Age Friendly Committee - Assisting Seniors in our Community**

6. **Items for Discussion and Reports**

**6.1 Charles Cosgrove, Manager, Facility and Parks, Community Services -
Trail System Final Drawings**

8

7. Correspondence

8. Announcements

9. Date of Next Meeting

The next meeting is scheduled for Thursday, November 14, 2024 at 10:00 a.m.

10. Adjournment



Minutes of Access Orangeville

September 12, 2024, 10:00 a.m.

Electronic and In-Person Participation - Access Orangeville

The Corporation of the Town of Orangeville

(Chair and Secretary at Town Hall - 87 Broadway)

Orangeville, Ontario

Members Present: Councillor R. Stevens, Chair
P. Charbonneau
S. Clarke
M. Hartley
J. Jackson
R. Ugolini
K. Van Ryn

Members Absent: K. Murphy-Fritz

Staff Present: G. Brennan, Legislative Assistant, Corporate Services
S. Doherty, Manager, Recreation and Events, Community Services
T. Dulisse, Manager, Transportation and Development, Infrastructure Services
J. Lavecchia-Smith, Deputy Clerk, Corporate Services
J. Rawn, Executive Assistant, Infrastructure Services

1. Call to Order

Councillor R. Stevens, Chair, called the meeting to order at 10:03 a.m.

2. Disclosures of (Direct or Indirect) Pecuniary Interest

None.

3. Land Acknowledgement

Councillor R. Stevens, Chair, acknowledged the treaty lands and territory of the Williams Treaty Nations and the Mississaugas of the Credit First Nation. He also recognized that Dufferin County is the traditional territory of the Wendat and the Haudenosaunee and is home to many Indigenous people today.

4. Adoption of Minutes of Previous Meeting

2024-018

Moved By J. Jackson

That the minutes of the following meeting are approved:

4.1 2024-06-13 - Access Orangeville - Minutes

Carried

5. Presentations

5.1 Jordyn Lavecchia-Smith, Deputy Clerk, Corporate Services, Town of Orangeville - Committee Governance

Jordyn Lavecchia-Smith, Deputy Clerk, Corporate Services, provided the Committee with a Committee Governance Refresher presentation. Mrs. Lavecchia-Smith discussed the various Boards, Committees, and Task Forces that advise Council on important matters. She shared details on the roles and responsibilities for Committee Members, the Chair, the Staff Liaison, and the Committee Secretary. She advised the Committee on the effectiveness of having an agenda, and how that contributes to the efficiency of a meeting. Mrs. Lavecchia-Smith clarified the decision-making process for when a motion is up for consideration, and the various outcomes when a motion is being voted on. Mrs. Lavecchia-Smith advised the Committee on next steps and plans for 2025.

5.2 Delegate - Grant Peters - Fare Free Transit

Grant Peters discussed the importance of having a Fare-Free Transit program operating in the Town of Orangeville. Mr. Peters shared details around the Town of Orangeville becoming one of the first municipalities to pilot a Fare-Free Transit program, and the blueprint it sets for surrounding municipalities. He discussed why transit needs to become more accessible – and affordable – for residents with the removal of the financial barrier for those who need it and can benefit from it the most. The committee discussed the positive impact the Fare-Free Transit program

has had on various community groups in Orangeville, and discussed the steps required to make transit more accessible and inclusive.

2024-019

Moved By M. Hartley

That the correspondence regarding the Fare-Free Transit Program be received, That Access Orangeville express their support of the Fair-Free Transit Program in principle, through a letter, and That the letter of support be included in the September 23 Council Agenda.

Carried

5.3 Delegate - Kylie-Anne Grube, Climate Engagement Specialist, Dufferin County - Community Resilience Hub

Kylie-Anne Grube, Climate Engagement Specialist, and Sara MacRae, Manager, Climate & Energy for Dufferin County, provided an overview of the County's Community Resilience Hub project. The Resilience Hub pilot project aims to design and install an outdoor structure that acts as a trusted neighborhood location that meets the everyday physical and social needs of a neighborhood and enhances their resilience during times of disruption and recovery. Ms. Grube and Ms. MacRae shared that resilience hubs provide an opportunity to effectively work at the nexus of community resilience and social equity while also providing opportunities for communities to become more self-determining, social connected, and successful.

Ms. Grube and Ms. MacRae provided details on what a resilience hub could look like:

- Everyday Mode - meets the daily needs of the neighbourhood, both physical and social,
- Disruption Mode - supports neighbourhoods during disruption events (e.g power outage, extreme weather event),
- Recovery Mode - supports neighbourhoods to recover after disruption event

The Committee discussed the following:

- The programs and services that could be offered at a community resilience hub,

- The need for accessible transportation options near potential community resilience hub locations,
- The features a community resilience hub would require to make the space accessible and inclusive for all,
- The challenges of a community resilience hub including maintenance of the space and graffiti markings.

Ms. Grube and Ms. MacRae advised the Committee on the All Access Toolkit: Guide on Application of Design of Public Spaces (DoPS) and the Integrated Accessibility Standards - Design of Public Spaces which are the guiding documents for accessibility. They shared that Phase one (1) of the project timeline: Feasibility and Engagement is ongoing. Phase two (2) Design, Engagement, and Implementation is scheduled to begin in 2025. The Committee provided details on upcoming community events for Ms. Grube and Ms. MacRae to attend and solicit additional feedback on this project.

6. Items for Discussion and Reports

6.1 Stop Gap Initiative

Sharon Doherty, Manager, Recreation and Events, Community Services provided the Committee with an update on the Stop Gap Initiative. She shared the following details:

- Project guidelines and planning is underway,
- The budget for the Stop Gap Initiative is included on the Committee's multiyear Work Plan, and
- That Town of Orangeville Staff will bring next steps to the Committee when they have an update to provide.

The Committee discussed working with the Orangeville Business Improvement Area (OBIA), the Community Improvement Committee, and additional local organizations when they are ready to roll out the Stop Gap Initiative.

6.2 Unique Inventions - Sledge Quote

The Committee discussed the roll out process for sledges at public skates. They discussed the need for information sessions, workshops for Staff, and advertisement opportunities. Sharon Doherty, Manager, Recreation and Events, Community Services, provided clarity to the Committee that

any individual will be able to use sledges and stressed the importance of being inclusive to all members of the public.

2024-020

Moved By K. Van Ryn

That Council direct staff to look into purchasing sledges on behalf of Access Orangeville at a total cost of \$10,000.

Carried

7. Correspondence

None.

8. Announcements

None

9. Date of Next Meeting

The next meeting is scheduled for Thursday, October 10 at 10:00 a.m.

10. Adjournment

2024-021

Moved By R. Ugolini

That the meeting be adjourned at 12:08 p.m.

Carried



Bike repair station

Trail bollard entrance

Backless Benches

Typical Trail Rest Area with leaning rail/bike rack and wheel chair accessible space beside bench.

Armour stone seating



Armour stone seating

Typical Trail Rest Area with leaning rail/bike rack and wheel chair accessible

Trail bollard entrance

Backless bench

Bike repair station

Squared Arch Bike Rack

Surface Mount Model (Shown): 850360

In-Ground Model: 850365

Size: 30" Wide x 5" Deep x 35" Tall

Capacity: 2 Bikes

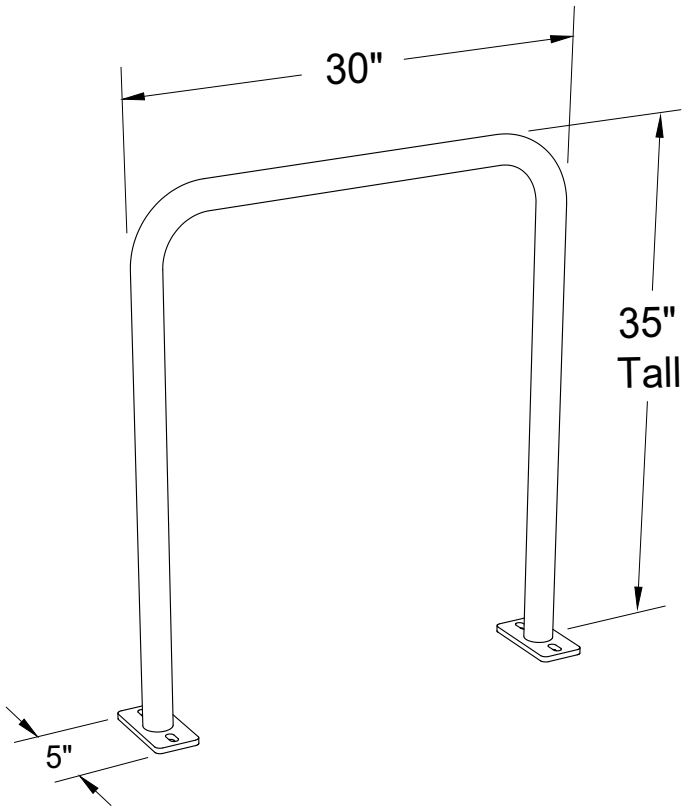

Squared Arch Bike Rack

with Custom Logo Plate

Surface Mount Model (Shown): 850370

In-Ground Model: 850375

Size: 30" Wide x 5" Deep x 35" Tall

Capacity: 2 Bikes

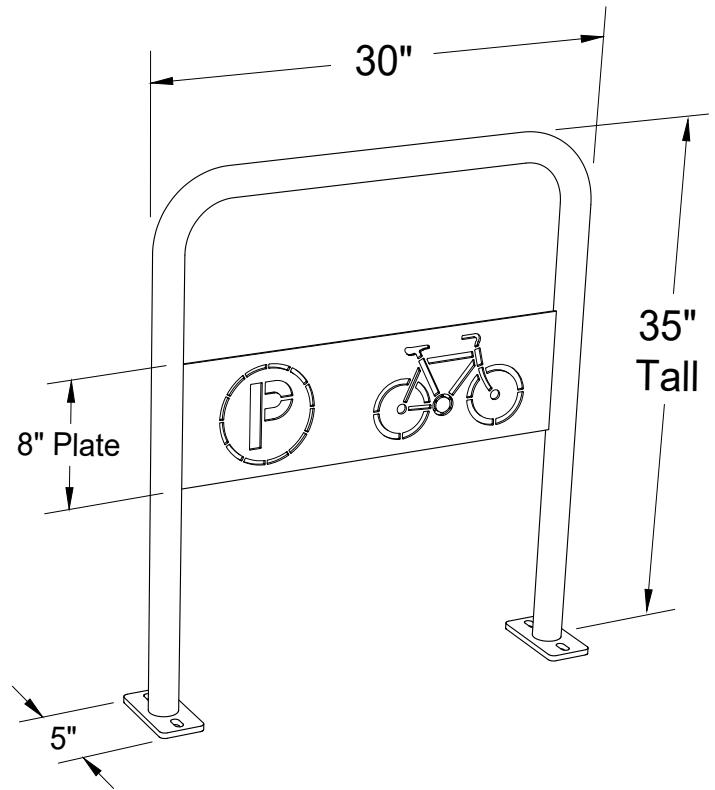

Description:

The Squared Arch Bike Rack conveniently parks 2 bikes yet maintains a slim profile when not in use. Excellent security is provided by the heavy gauge round steel tubing.

Available in both Surface Mount and In-Ground/Embedded configurations.

Parks 2 bikes.

Description:

The Squared Arch Bike Rack conveniently parks 2 bikes yet maintains a slim profile when not in use. Excellent security is provided by the heavy gauge round steel tubing.

The Custom Logo Plate provides a location for advertising, identification or commemorative text. The plate can be provided with custom laser-cut graphics or as a blank plate suitable for applied vinyl graphics.

Available in both Surface Mount and In-Ground/Embedded configurations.

Parks 2 bikes.